

Patch Panel Cat. 6 48 Ports INFINI+E

- NOTES:**
1. MATERIAL : ST-12 T=1.6mm AFTER POWDER COATING.
 2. BODY COLOR : BLACK.

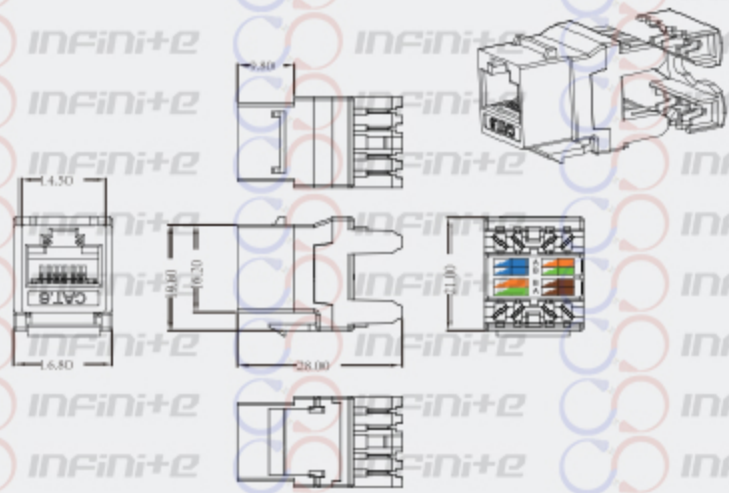

- NOTES:**
- ELECTRICAL:**
1. VOLTAGE RATING : 125 VAC RMS
 2. CURRENT RATING : 1.5 AMP
 3. CONTACT RESISTANCE : 20 MILLIOHMS MAX
 4. INSULATION RESISTANCE : 100 MEGOHMS MIN @ 500 VDC
 5. DIELECTRIC STRENGTH : 750 VAC RMS 60Hz, 1MIN
 6. C6 PERMANENT LINK : CONFORM TO ANSI/TIA/EIA-568 B.2-1
- ENVIRONMENTAL:**
1. STORAGE : -40° TO +70°
 2. OPERATION : -10° TO +60°
- MATES WITH MODULAR PLUG CONFORMING TO FCC PART 68, SUBPART F.
- MECHANICAL:**
1. HOUSING MATERIAL : PC
 2. INSERT MATERIAL : PC
 3. PCB MATERIAL : FR-4 T=1.2mm
 4. CONTACT MATERIAL : PHOSPHOR BRONZE STAMP PIN T=0.35mm
 5. IDC CONTACT MATERIAL : PHOSPHOR BRONZE T=0.50mm WITH TIN PLATING
 6. RJ45 JACK LIFE : 750 TIMES MIN
 7. IDC LIFE : 200 TIMES MIN
 8. WIRE : AWG 22-24
 9. TIA Cat 6 Perm. Link Test: Worst pair NEXT margin \geq 3.0dB
 10. Retentiveness of insertion structure: 50N 60 \pm 5s